

Effective date: 2023-06-15
Status:Approved



Class Rules

International 470 Class Association



The 470 Class was designed in 1963 by Andre Cornu and was adopted as a World Sailing class in 1969.

sport / nature / technology



INDEX

INTRODUCTION	3	C.5	Portable Equipment	9	
PART I – ADMINISTRATION		C.6	Boat	9	
Section A – General		C.7	Hull	10	
A.1	Language	4	C.8	Hull Appendages.....	10
A.2	Abbreviations	4	C.9	Rig	11
A.3	Authorities.....	4	C.10	Sails	13
A.4	Administration of the Class	4	Section D– Hull		
A.5	WS Rules	4	D.1	General	16
A.6	Class Rules Variations	5	D.2	Buoyancy Tanks	17
A.7	Class Rules Amendments	5	D.3	Assembled Hull	17
A.8	Class Rules Interpretations	5	D.4	Measurement Diagrams.....	19
A.9	International Class Fee and WS Building Plaque	5	Section E – Hull Appendages		
A.10	Sail Numbers	5	E.1	Rules	25
A.11	Hull Certificate	5	E.2	Manufacturers	25
A.12	Initial Hull Certification	6	E.3	Centreboard	25
A.13	Validity of Certificates	6	E.4	Rudder blade, Stock & Tiller	27
A.14	Hull Re-Certification	6	Section F – Rig		
A.15	Retention of Measurement Forms	6	F.1	Rules	30
Section B – Boat Eligibility		F.2	Manufacturers	30	
B.1	Class rules and Certification	7	F.3	Mast.....	30
B.2	Flotation Checks	7	F.4	Boom	32
B.3	ICA Labels	7	F.5	Spinnaker Pole	33
PART II – REQUIREMENTS AND LIMITATIONS		F.6	Standing Rigging	33	
Section C – Conditions for Racing		F.7	Running Rigging	33	
C.1	General	8	F.8	Other Rigging.....	34
C.2	Crew	8	Section G – Sails		
C.3	Personal Equipment	8	G.1	Parts	35
C.4	Advertising	9	G.2	General	35
			G.3	Mainsail	36
			G.4	Jib	37
			G.5	Spinnaker	39

INTRODUCTION

This introduction only provides an informal background and the International 470 Class Rules proper begin on the next page.

The 470 is a One-Design racing dinghy with an overall length of 4.70m for a crew of two, designed by Andre Cornu in 1963 and adopted as an International/Recognized class in 1969 and became an Olympic Class in 1976 where the class was sailed as an open event before the introduction of separate events for men and women in 1988 For 2024 the class will be sailed as a Mixed event.

Class rules may evolve, while the intention is to avoid the use of costly, short-lived, risky or environmentally improper materials.

470 hulls, hull appendages, rigs and sails are measurement controlled.

Rules regulating the use of equipment during a race are contained in Section C of these class rules, in Equipment Rules of Sailing Part I and in the Racing Rules of Sailing.

Owners and crews should be aware that compliance with rules in Section C is not checked as part of the certification process.

PART I – ADMINISTRATION

Section A – General

A.1 LANGUAGE

- A.1.1 The official language of the class is English and in case of dispute over translation the English text shall prevail.
- A.1.2 The word “shall” is mandatory and the word “may” is permissive.
- A.1.3 The term "secured" shall mean held in place by positive means.
- A.1.4 The term "fastened" shall mean held in place with bolts, screws or rivets.
- A.1.5 The term "permanent" shall mean unable to be removed with simple tools, or fixed with glue or rivets or by glassing over. For limit marks, it shall mean unable to be removed and repositioned without destroying them.
- A.1.6 The term "alteration" shall mean a substantial change from the original condition.
- A.1.7 A dimension or other requirement in the text overrides the same in a Figure.
- A.1.8 All units are metric.
- A.1.9 All dimensions are in millimetres.

A.2 ABBREVIATIONS

- A.2.1 WS World Sailing
- MNA World Sailing Member National Authority
- ICA International 470 Class Association (470 Internationale)
- NCA National 470 Class Association
- ERS Equipment Rules of Sailing
- RRS Racing Rules of Sailing

A.3 AUTHORITIES

- A.3.1 The **class rules authority** is WS, which shall co-operate with the ICA in all matters concerning these **class rules**.
- A.3.2 The **certification authority** in each country is the ICA, which may delegate this function to the respective MNA or NCA.
- A.3.3 Neither WS, an MNA, the ICA, an NCA, a **certification authority**, or an **official measurer** are under any legal responsibility in respect of these class rules and the accuracy of measurement, nor can any claims arising from these be entertained.
- A.3.4 Notwithstanding anything contained herein, the **certification authority** has the authority to withdraw a **certificate** and shall do so on the request of WS or the ICA.

A.4 ADMINISTRATION OF THE CLASS

- A.4.1 WS has delegated its administrative functions of the class to the ICA. The ICA may delegate part or all of its functions, as stated in these **class rules**, to an NCA.
- A.4.2 In countries where there is no NCA, or the NCA does not wish to administrate the class, its administrative functions as stated in these **class rules** shall be carried out by the ICA which may delegate the administration to the respective MNA.

A.5 WS RULES

- A.5.1 These **class rules** shall be read in conjunction with the current version of ERS and RRS.
- A.5.2 Except where used in headings, when a term is printed in “**bold**” the definition in the ERS applies and when a term is printed in “*italics*” the definition in the RRS applies.
- A.5.3 These rules are complementary to the Building Specification Plan and the Measurement Form.

A.6 CLASS RULES CHANGES

- A.6.1 At World, Continental or Regional Championships the Notice of Race and/or the Sailing Instructions may change the **class rules** only with the agreement of the ICA and WS.
- A.6.2 At National events the Notice of Race and Sailing Instructions may change the **class rules** only with the agreement of the ICA and the respective NCA.
- A.6.3 At any other class events, these **class rules** may be changed by the Notice of Race or Sailing Instructions only with the agreement of the ICA.

A.7 CLASS RULES AMENDMENTS

- A.7.1 Amendments to these **class rules** are subject to the approval of WS in accordance with the WS Regulations.

A.8 CLASS RULES INTERPRETATIONS

- A.8.1 Interpretation of **class rules** shall be made in accordance with the WS Regulations.

A.9 INTERNATIONAL CLASS FEE AND WORLD SAILING PLAQUE

- A.9.1 The licensed hull builder shall pay the International Class Fee and then will receive the corresponding WS building plaque for each hull built. No hull shall leave the builder’s premises without the WS building plaque installed as per D.1.4 (a).

A.10 SAIL NUMBERS

- A.10.1 Sail numbers shall be issued by the NCA of the country where the boat is registered, which may delegate this function to the MNA.
- A.10.2 Sail numbers shall be issued in consecutive order per country starting at “1”.
- A.10.3 In accordance with RRS Appendix G1.1 (c), the MNA or NCA may issue personal sail numbers (Sail numbers staying with the owner for every boat he legally possesses as long as he sails 470) for which the authority may raise a fee. This number must be shown on the Certificate and shall not conflict with existing numbers of active boats. After the sale of the boat, the new owner has to use her original sail number or his own personal number on his sails.
- A.10.4 Competitors may use the sail number of any hull still owned by them, on any boat chartered or owned by them.

A.11 HULL CERTIFICATE

- A.11.1 No boat shall take part in class races unless it has a valid measurement **certificate** in the owner's name. The measurement **certificate** is only valid if the owner is a current member of a NCA or, if there is no NCA in his nation, Individual Member of the ICA as per the ICA Constitution.
- A.11.2 A **certificate** shall record the following information:

- (a) Class
- (b) **Certification authority**
- (c) Sail number(s) in accordance with A.10.
- (d) Owner's name and address.
- (e) Hull identification as per D.1.4
- (f) Builder / manufacturer's details
- (g) Date of issue of **certificate**

A.12 INITIAL HULL CERTIFICATION

A.12.1 For a **certificate** to be issued to a hull not previously **certified**:

- (a) **Hull certification control** shall be carried out by an **official** measurer who shall complete the measurement form, before the hull leaves the builder's premises.
- (b) The measurement form and any **certification** fee if required, shall be sent to the **certification authority**.
- (c) Upon receipt of a satisfactorily completed measurement form(s) and **certification** fee, if required, the **certification authority** may issue a **certificate**.

A.13 VALIDITY OF CERTIFICATES

A.13.1 A hull **certificate** becomes invalid upon:

- (a) the change to any items recorded on the hull **certificate** as required under A.11.2
- (b) the date of expiry, if any.
- (c) withdrawal by the **certification authority**,
- (d) the issue of a new **certificate**.

A.13.2 Older hulls need not be re-certified if the rules under which they were built are changed (grandfather rule).

A.14 HULL RE-CERTIFICATION

A.14.1 The **certification authority** may issue a new **certificate** to a previously certified hull:

- (a) When the certificate has become invalid under A.13.1 (a) or (b), after receipt of the old **certificate**, and **certification** fee if required.
- (b) When the certificate has become invalid under A.13.1 (c), at its discretion.
- (c) In other cases, by application of the procedure required for initial hull **certification**.

A.15 RETENTION OF MEASUREMENT FORMS

A.15.1 The **certification authority** shall:

- (a) retain the original measurement form(s) upon which the current **certificate** is based and shall provide the owner with a certified true copy of the measurement form.
- (b) upon request, transfer the measurement form to the new **certification authority** if the hull is exported.

Section B – Boat Eligibility

For a **boat** to be eligible for *racing*, it shall comply with rules in this section.

B.1 CLASS RULES AND CERTIFICATION

- B.1.1 The boat shall;
- (a) Be in compliance with the **class rules**.
 - (b) Have a valid **hull certificate** and **hull** measurement form.
 - (c) have valid **certification marks** as required

B.2 FLOTATION CHECKS

- B.2.1 It is the responsibility of the owner to ensure at all times the water-tightness of the boat.

B.3 ICA LABELS

- B.3.1 Sails shall carry a sail button / sticker issued by the ICA. See G.2.2(b)

PART II – REQUIREMENTS AND LIMITATIONS

The **crew** and the **boat** shall comply with the rules in Part II when *racing* and when *rules* specify. The Notice of Race may specify that compliance shall be in effect from the moment equipment is presented for event **inspection**. Measurement to check conformity with rules of Section C is not part of equipment **certification control**.

The rules in Part II are **closed class rules**. Measurement shall be carried out in accordance with the current version of ERS except where varied in this Part.

Fittings may be combined as long as no additional not-permitted function is added.

Section C – Conditions for Racing

C.1 GENERAL

C.1.1 RULES

(a) The following RRS rules shall apply as amended below:

- (1) If the average wind speed is clearly over 10 knots across the course the race committee may signal in accordance with RRS Appendix P5 that pumping, rocking and ooching are permitted. This changes rules RRS 42.2(a), RRS 42.2(b), RRS 42.2(c).
- (2) RRS 49.1 is changed to: 'A crew member shall use no device designed to position his body outboard other than a **trapeze**, hiking straps and hiking aids worn under the thighs.
- (3) See C.3.2 (a) and C.3.3(a) for amendments to RRS 50.1(b) and C.10 for changes to RRS Appendix G.
- (4) RRS 50.1(c) is changed as permitted by the rule itself, to allow the use of trapeze harnesses that are not of the quick release variety.

(b)

- (1) The ERS Part I – Use of Equipment shall apply except where varied by these rules.
- (2) Rule G.2.1(d) modifies ERS H.5.4.

C.2 CREW

C.2.1 LIMITATIONS

- (a) The **crew** shall consist of two persons.
- (b) No **crew** member shall be substituted during an event, unless authorised by the Race Committee.
- (c) The **trapeze** system shall not be used by more than one **crew** member at any time. A **crew** member using a **trapeze** shall be in contact with the **hull** at all times except in the situation of accidental movement and/or a manoeuvre.

C.2.2 CLASS MEMBERSHIP

- (a) The **crew** shall be current members of a NCA who shall be in good standing with the ICA, or if there is no NCA in their country, the **crew** shall be current Individual Members of the ICA. A Notice of Race may change this rule.

C.3 PERSONAL EQUIPMENT

C.3.1 MANDATORY

- (a) The **boat** shall be equipped with a **personal flotation device** for each **crew** member to the minimum standard ISO 12402-5, or USCG Type III, or AS 4758 Level 50 or equivalent. Inflatable **personal flotation devices** are not permitted.

C.3.2 OPTIONAL

- (a) Trapeze harness. The weight shall not exceed 3 kg, measured according to RRS Appendix H.
- (b) Electronic or mechanical timing devices which may include a compass but do not have any other function/capability.
- (c) A heart rate monitor with no additional function/capability.

C.3.3 TOTAL WEIGHT

- (a) In accordance with RRS 50.1(b), the total weight of personal equipment worn, excluding trapeze harness and clothing (including footwear) worn below the knee shall not exceed 9 kg, measured according to RRS Appendix H.

C.4 ADVERTISING

C.4.1 LIMITATIONS

Advertising shall only be displayed in accordance with the WS Advertising Code. See WS Regulation 20.

C.5 PORTABLE EQUIPMENT

C.5.1 FOR USE

(a) OPTIONAL

- (1) One hand bailer or bucket.
- (2) Not more than 2 magnetic compasses having no electronics, or one electronic self-contained compass using magnetic input from fluxgate sensors. If electronic, the compass may have only heading and timing functions. The display may show only the following:
 - heading (damping may be adjusted manually),
 - heading \pm a tacking angle (which may be adjusted manually),
 - time,
 - race timing information,
 - identification,
 - battery condition, system error, adjustment and calibration information.Race timing information may be transmitted by sound. The electronic compass shall not deliver, store or correlate information in any way except as described here.
- (3) Electronic or mechanical timing devices which shall be removable. No other electrical or electronic devices than those prescribed in C.3.2 & C.5.1 and those required by an organizer and the ICA to be carried by boats shall be permitted on board when *racing*.
- (4) Tools and spare parts such as blocks, shackles, ropes, etc.

C.5.2 NOT FOR USE

(a) MANDATORY

(1) Towing rope of floating type with a minimum length of 10m and of not less than 8mm in diameter. It shall not be stored inside a buoyancy tank.

(b) OPTIONAL

(1) One paddle.

C.6 BOAT

C.6.1 WEIGHT

Minimum

The weight of the **boat** shall be 120 kg,
measured with the **boat** in dry condition, including compasses, but excluding **sails**, jib luff wire and all **portable equipment**.

C.6.2 CORRECTOR WEIGHTS

(a) When the **boat** weight is less than the minimum, **corrector weights** shall be fastened under the mast partner or to the top of the forward bulkhead.

(b) The total weight of such **corrector weights** shall not exceed 2.0 kg.

C.6.3 FLOTATION

(a) If in doubt regarding compliance with B.2, an **equipment inspector** may order a buoyancy test, afterwards checking the tanks for significant leakage. If the buoyancy is deemed unsatisfactory, the **certificate** shall be withdrawn and not returned until satisfactory remedial measures have been taken.

C.6.4 FITTINGS

(a) Non-slip material not exceeding 4mm in thickness, padding for protection of equipment, tape and low-friction material may be added anywhere in the boat as long as it does not change the stiffness of that part, except where restricted by these **class rules**.

(b) All **fittings**, fastenings and local reinforcement for fittings shall be only for their normal purpose and shall not be used to increase the weight of the **boat** or its parts.

C.7 HULL

C.7.1 MODIFICATIONS AND MAINTENANCE

(a) The hull shell, deck, bulkheads, centreboard case and cockpit floor as supplied by the licensed builder shall not be **modified** in any way except as permitted by these **class rules**.

(b) Routine **maintenance** such as small **repairs**, painting, **sanding** and polishing is permitted without re-measurement and re-**certification**.

(c) If any hull moulding is repaired in any other way than described in C.7.1(b), an **official measurer** shall verify on the **certificate** that the external shape is the same as before the repair and that no substantial increase in stiffness, or other, advantage has been gained as a result of the repair. The **official measurer** shall also describe the details of the repair on the **certificate**.

C.7.2 FITTINGS

(a) FOR USE

- (1) Inspection hole covers and drainage plugs shall be kept in place at all times when *racing*.
- (2) Except when specified otherwise or where a control system is optional, the direction of the control lines, sheets and ropes shall not be modified by means of shackles, rings, loops or holes in the boat.

C.8 HULL APPENDAGES

C.8.1 LIMITATIONS

- (a) Only one **centreboard** and one **rudder** blade shall be used during an event, except when a **hull appendage** has been lost or damaged beyond repair.

C.8.2 CONDITIONS FOR USE, CENTREBOARD

- (a) No part of the **centreboard**, in its raised position, shall project below the **hull**.
- (b) Strips of any material and of a minimum length of 300mm and maximum width of 30mm to reduce friction and/or the distance between the centreboard and centreboard case, permanently installed within 35mm from the upper and/or lower ends of the centreboard case. Centreboard protective padding may be installed at the first 10 mm of the lower front end of the case.
- (c) No **fitting** or device shall be attached, installed or applied to the inside of the centreboard case that may cause the centreboard to gybe (angle to windward).

C.8.3 CONDITIONS FOR USE, RUDDER

(a) RUDDER

The **rudder** blade shall be in its fully lowered position when *racing*. However, it may be raised momentarily to clear sea weed or other floating objects. For races sailed in shallow water, the Sailing Instructions may prescribe that this rule shall not apply.

(b) RUDDER ASSEMBLY

The **rudder** assembly shall consist of a rudder blade, a rudder stock and a tiller with an optional tiller extension. The rudder blade shall be able to pivot around its axis. The rudder assembly shall be detachable from the **hull**.

When mounted on the **hull**, the rudder blade pivot shall be located at a maximum of 150 mm abaft the transom and its height above the lower corner of the transom shall be a minimum of 120 mm, measured according to the Figure "Rudder Pivot Position".

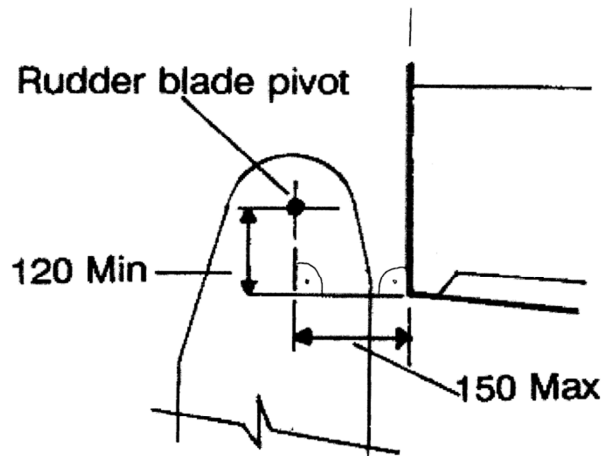

Rudder Pivot Position

C.8.4 **MAINTENANCE**

Routine **maintenance** such as small **repairs**, painting, **sanding** and polishing is permitted.

C.9 **RIG**

C.9.1 LIMITATIONS

(a) Only one **mast**, **boom** and **spinnaker pole** shall be used during an event except when an item has been lost or damaged beyond repair.

C.9.2 CONDITIONS FOR USE, MAST

(a) USE

(1) The fore and aft bend of the mast **spar** may be controlled at the mast partner by one of the following devices:

- (i) Chocks between the mast **spar** and the mast partner (forward of the mast).
- (ii) Optional systems of ropes or wires which may include attachments, blocks, levers, grips and cleats, all located on top of the mast partner.

With the mast spar in its most forward position, the grip, end of rope, wire or other parts of the system of the aft bend control shall not be more than 150mm from the mast partner as Figure "Mast Controller Grip" shows:

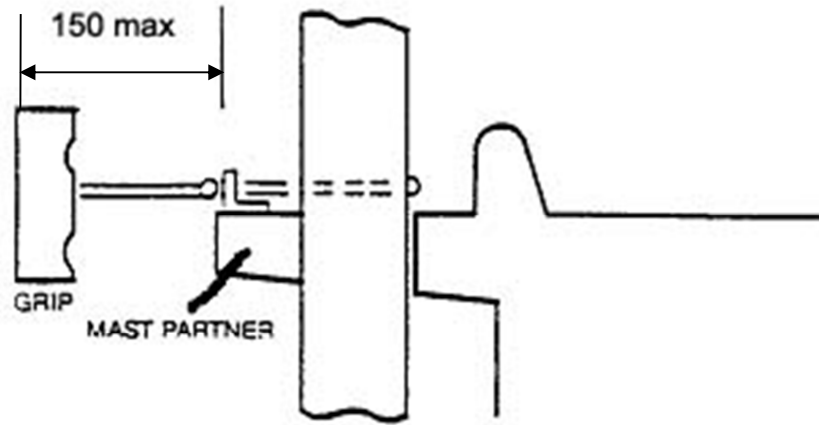

Mast Controller Grip

With the mast in its aft most position the grip of the forward bend control shall not be more than 150mm from the mast partner.

- (2) The sideways play between the **mast spar** and the mast partner may be controlled by strips of any material permanently **installed** on the mast partner.
- (3) The mast heel position shall not be adjusted when *racing*.
- (4) The forestay under tension shall be entirely in metal and shall prevent the mast from disengaging from the mast partners. To meet this requirement the widest section of the mast shall be within the mast partners when the mast rakes under its own weight and the forestay comes under tension, as Figure "Mast Rake with Tensioned Forestay" shows:

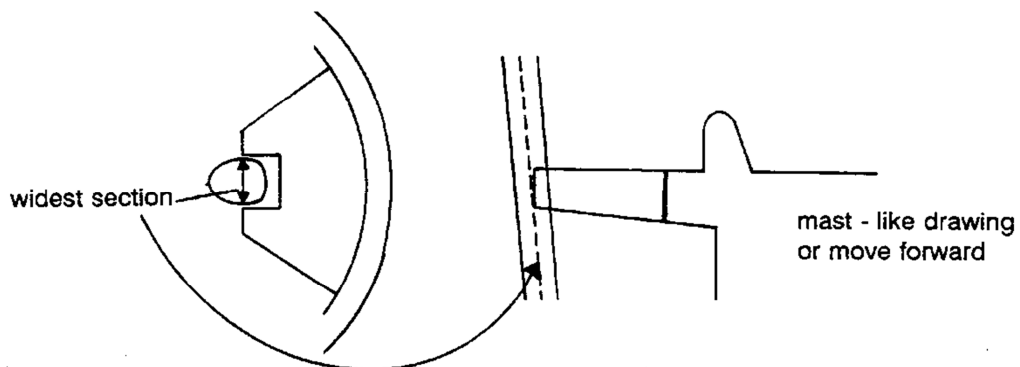

Mast Rake with Tensioned Forestay

- (5) Adjustable **spreaders**, if used, shall not be remotely controlled, and shall not be adjusted when *racing*.

C.9.3 CONDITIONS FOR USE, STANDING RIGGING

- (1) The effective length of the **shrouds** shall not be adjusted when *racing*.

C.9.4 CONDITIONS FOR USE, RUNNING RIGGING

- (1) **Sails** and **sheets** may be moved directly by hand without the use of a block.

C.9.5 MAINTENANCE

- (a) Routine **maintenance** such as small **repairs**, painting, **sanding** and polishing is permitted.

C.10 SAILS

C.10.1 MODIFICATIONS AND MAINTENANCE

- (a) Routine **maintenance** such as sewing, mending and patching is permitted without re-**certification**.

C.10.2 LIMITATIONS

- (a) Not more than one mainsail, one jib and one spinnaker shall be carried aboard when *racing*.
- (b) Not more than one **mainsail**, one **jib** and one **spinnaker** shall be used during an event, except when a **sail** has been lost or damaged beyond repair.

C.10.3 IDENTIFICATION

- (a) The **mainsail** and **spinnaker** shall carry as sail identification the national letters and sail number. The sail number to be carried on the sails shall correspond to the last four digits of the official sail number issued according to A.10. The national letters and sail numbers size and position shall comply with the RRS Appendix G.1.2 and G.1.3 except where otherwise prescribed in these class rules.

C.10.4 MAINSAIL

(a) IDENTIFICATION

- (1) The sail identification shall be red, in paint or durable material, securely attached. It shall be placed as shown in the Figure "Sail Identification Location", and so that the characters on one side of the sail do not overlap with characters on the other side, leaving at least 60 mm in between. These change RRS Appendix G.1.3(c).



Sail Identification Location

- (2) Mainsails used in women's only events shall carry a red rhombus (length of diagonals minimum 240mm, maximum 260mm) above the top batten pocket on both sides. The position should be approximately in the centre of the triangle formed by the top batten and the mainsail head. The rhombus may be retained for racing in other events. This changes RRS G.1.1(a)
- (3) The 470 mainsail insignia as per Class Rule G.3.1 may be replaced by either:
 - i) a gold version conforming to the same dimensions when at least one **crew** member is an Olympic or World Champion, or
 - ii) a silver version conforming to the same dimensions when at least one **crew** member has won the Open European Championship.
- (4) At WS Sailing World Cup events and the WS Sailing World Championships, or when required by a Notice of Race, the helmsman's national flag, nominal size 740 x 443 mm, shall be applied to each side of the **mainsail**, placed as shown in the Figure "Mainsail Flag Location", so that the shortest distance of the lower aft corner of each flag is between 50 and 100 mm from the **leech** and the upper edge between 50 and 100 mm below the lowermost **batten pocket**. The flags shall be made by a WS approved manufacturer as listed at the 470 "World Sailing Classes" section of the WS website:

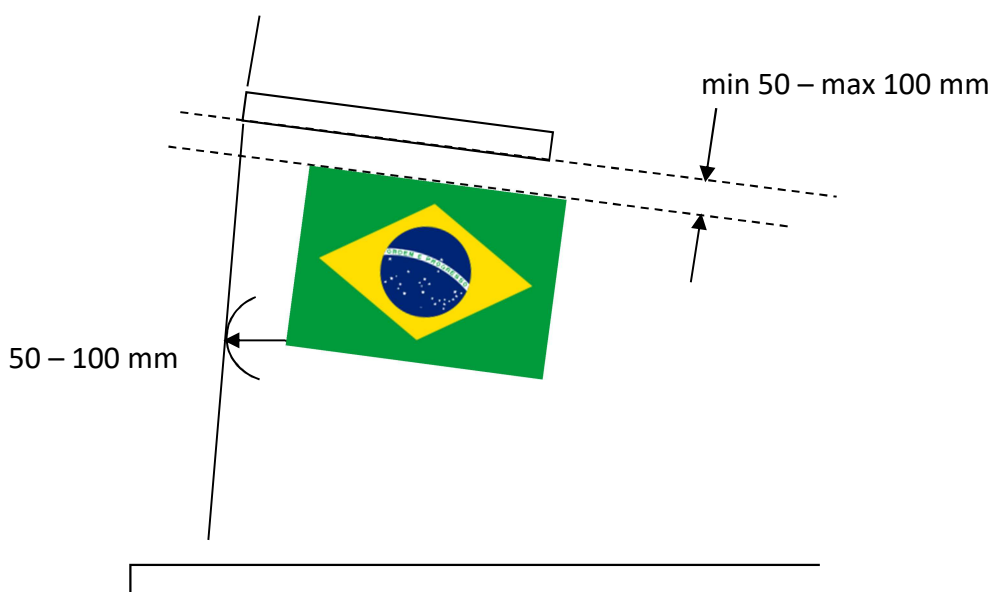

Mainsail Flag Location

(b) USE

- (1) The **sail** shall be hoisted on a halyard. The arrangement shall permit hoisting and lowering of the **sail** at sea with the boat upright.
- (2) **Luff** and **foot** bolt ropes shall be set in the **mast** and **boom spar** grooves or tracks respectively.
- (3) Battens shall be fitted, except in the case of accidental loss.
- (4) The **sail** shall be set so that the highest visible point of it, projected at 90° to the **mast** spar, shall not be higher than the **upper point**. This changes ERS B.1.1.
- (5) The **sail** shall be set so that the aftmost visible part of the leech, projected at 90° to the boom, is at or forward of the **outer point**. This changes ERS B.1.3.

C.10.5 JIB

(a) USE

- (1) The **jib** shall be hoisted and lowered on a halyard. The arrangement shall permit hoisting and lowering of the sail at sea with the **boat** upright.
- (2) Only one stainless steel luff wire of diameter not less than 2.3mm and the optional **jib head** adjustment line shall be fitted inside the jib luff sleeve.

C.10.6 SPINNAKER

(a) IDENTIFICATION

- (1) Identification shall be of a contrasting colour to the **body of the sail**.
- (2) As an alteration to RRS Appendix G, national letters may be positioned in line with the sail numbers.

Section D – Hull

D.1 GENERAL

D.1.1 RULES

- (a) The **hull** shall comply with the **class rules** and official plans in force at the time of initial **certification**, but all fittings shall comply with the current rules.
- (b) For boats first certified after the 1st of March 1993, the hull shall be constructed in accordance with the Building Specification Plan and shall consist of the parts listed therein except where temporary alternatives have been approved for the builder by WS in writing. All boats from any one builder shall be built to the same detailed specification submitted by the builder to WS. Any subsequent modifications have to be approved by WS before implementation and such approval will not be granted inside the 6-month period before the first scheduled start of the Olympic Sailing Competition.

D.1.2 CERTIFICATION

See Rule A.12.

D.1.3 DEFINITIONS

(a) HULL DATUM POINT

The **hull datum point** (HDP) is the projection of the AMP on the baseline.

(b) AFT MEASURING POINT

The aft measuring point (AMP) is the intersection on the hull centre plane of the transom external surface with the underside of the hull surface, both extended as necessary.

(c) FORWARD MEASURING POINT

The forward measuring point (FMP) is the **sheer** point on the stem, as shown in the Measurement References diagram.

- (d) Unless otherwise stated, all measurements shall be taken parallel to the baseline.

D.1.4 IDENTIFICATION

- (a) The **hull** shall carry the WS Building Plaque permanently affixed to the starboard side tank close to the transom and cockpit floor.
- (b) The **hull** shall carry, either moulded in or on a permanently affixed plate, the builder's mark, serial number and mould number, which also appear on the measurement form and **certificate**. In addition, the builder's serial number shall be moulded or engraved on the outside of the transom on the starboard side.

D.1.5 BUILDERS

- (a) The **hull** shall be built by a builder licensed by WS. **Hulls** shall be supplied only as permanently assembled boat units.
- (b) All moulds shall be approved by WS.
- (c) Application for a licence shall be made through a MNA to WS. The licences shall include clauses requiring good standards of manufacture, compliance with class rules and plans and a guarantee that all fees shall be paid. WS shall consult with the ICA before granting any licence and only sufficient licences will normally be

issued in a country to ensure that demand is satisfied. No new builder licenses or approval for new moulds from existing builders will be granted inside the 6-month period before the first scheduled start of the Olympic Sailing Competition.

- (d) Alteration to approved moulds and or the building specification made without the approval of WS shall result in the builder's licence being revoked. This same measure shall be taken in case of intentional and/or repeated infringements of the **class rules**, by the builder.

D.1.6 MATERIALS

- (a) Only materials in accordance with the Building Specification shall be used. Local reinforcement of GRP, wood, plywood or metal as backing for **fittings** may be added.

D.2 BUOYANCY TANKS

D.2.1 CONSTRUCTION

- (a) Buoyancy equipment shall comprise of two foam buoyancy blocks located in the side tanks, one piece in each tank. The minimum volume is 0.05 m³ each, with a minimum length of 1500mm, according to the building specification.

D.3 ASSEMBLED HULL

D.3.1 FITTINGS

(a) MANDATORY

The following fittings shall be positioned in accordance with the Building Specifications unless otherwise noted:

- (1) Stemhead fitting. Only the hole specified in the measurement form as the jib tack attachment point shall be used for this purpose.
- (2) Shroud plates with only one attachment position for the **shroud**.
- (3) Mainsheet track and/or metal reinforcement, which shall be straight.
- (4) Mast step, which may incorporate means of fore and aft adjustment and which shall bear a mark at 3055mm from the AMP, engraved on the mast step or its mouldings. Additional dimensions for the mast step are mentioned in D.3.2.
- (5) Two rudder fittings, bolted to the transom and a device to prevent the rudder assembly from becoming detached from the hull.

(b) OPTIONAL

- (1) Jib and spinnaker halyard control systems.
- (2) An aft and/or centre mainsheet system may be used. Fittings and the adjustment system are optional, except that if a hoop is used, it shall be of aluminium and/or stainless steel.
- (3) Mainsail Cunningham adjustment system.
- (4) Kicking strap (boom vang) adjustment system.
- (5) Jib sheet blocks, fairleads and cleats.
- (6) Jib tack adjustment system-
- (7) Fixed or adjustable jib sheet fairleads or pulleys. If traveller tracks are used, no more than one traveller car per track is permitted. Adjustment of the jib

fairleads or pulleys may be remotely controlled only in one direction (e.g. fore/aft or in/out or up/down). Additional adjustments to the fairleads or pulleys are only permitted by means of prefixed positions.

- (8) Spinnaker sheet and guy adjustment system.
 - (9) Spinnaker sheet barber hauler adjustment system.
 - (10) Spinnaker pole uphaul/downhaul adjustment system.
 - (11) Fixed or adjustable toe straps fitted within the cockpit.
 - (12) Fittings for stowage of paddle, spinnaker pole and other equipment
 - (13) A maximum of two self-bailers, with a total effective area not exceeding 12.5 cm².
 - (14) Spinnaker catcher device(s) which shall not project: more than 150 mm in front of the bow, or outside the outboard edge of the gunwale.
 - (15) Sealing strips (gaskets) for the centreboard slot of optional material in the recess shown in the Building Specification.
 - (16) Optional centreboard uphaul/downhaul adjustment system.
 - (17) Hinged covers or other devices for closing draining ports or drain holes in the transom. These covers or devices shall not obstruct the rudder or act as an extension of the bottom of the hull.
 - (18) A single position centreboard pivot including bushing.
 - (19) Trapeze return system(s) with elastic cord and blocks/fairleads.
 - (20) Jib head adjustment system.
- (c) **Fittings** may be attached to brackets not exceeding 175mm x 125mm.
- (d) No **fittings**, with the exception of spinnaker sheet catcher(s), rudder fittings and transom drainage flaps shall project beyond the outboard edges of the gunwale rubbing strips or beyond the profile of the hull,
- (e) No **fitting** shall serve as an extension of the hull surface.
- (f) Control lines and/or sheets shall not pass through the buoyancy compartments or the breakwater.
- (g) No **Ballast** other than required **corrector weights** shall be carried.
- (h) Materials for permitted **fittings** are optional.

D.3.2 DIMENSIONS

The keel line shall be taken as the intersection line from transom to stem of the hull shell and the hull centerplane.

The sections shall be taken as, transverse planes perpendicular to the baseline at the following positions:

- Section 1: at 500 mm from **hull datum point**.
- Section 2: at 1000 mm from **hull datum point**.
- Section 3: at 1500 mm from **hull datum point**.
- Section 4: at 2000 mm from **hull datum point**.
- Section 5: at 2500 mm from **hull datum point**.
- Section 6: at 3000 mm from **hull datum point**.
- Section 7: at 3500 mm from **hull datum point**.
- Section 8: at 4000 mm from **hull datum point**.

Section 9: at 4500 mm from **hull datum point**.

The baseline shall be on the centerplane of the **hull** at the following vertical distances:
 at the **hull datum point**: 230 mm from the AMP
 at section 8 : 114 mm from the hull shell.

	minimum	maximum
Length of hull between AMP and FMP.....	4690 mm	4710 mm
Vertical distance from baseline to underside of hull shell;		
at section 1.....	174 mm	182 mm
at section 2.....	129 mm	139 mm
at section 3.....	92 mm	104 mm
at section 4.....	67 mm	81 mm
at section 5.....	54 mm	68 mm
at section 6.....	56 mm	66 mm
at section 7.....	72 mm	80 mm
Longitudinal distance from hull datum point		
to centre of shroud plate holes:2770 mm 2790 mm
Fore and aft position of aft edge of the mast, projected		
from above the sail entry at step level from hull		
datum point	3055 mm 3115 mm
Mast step bearing surface above the keelson		
when fitted.....	 5 mm
Mainsheet track and/or metal reinforcement shall be attached to the top of the		
centerboard case and mounted at a distance from the		
hull datum point of.....	1610 mm 1650mm
Inside diameter of buoyancy tank inspection holes	110 mm 160 mm
Inside diameter of buoyancy tank draining holes.....	10 mm 25 mm

D.3.3 WEIGHT

	minimum	maximum
Hull weight (refer to building specification)	86.0 kg kg

D.4 MEASUREMENT DIAGRAMS

Note:

- (1) This part of the Class Rules makes reference to the Building Specification Plan.
- (2) Only templates from a supplier approved by WS and the ICA shall be used for hull measurement.

D.4.1 HULL DATUM POINT

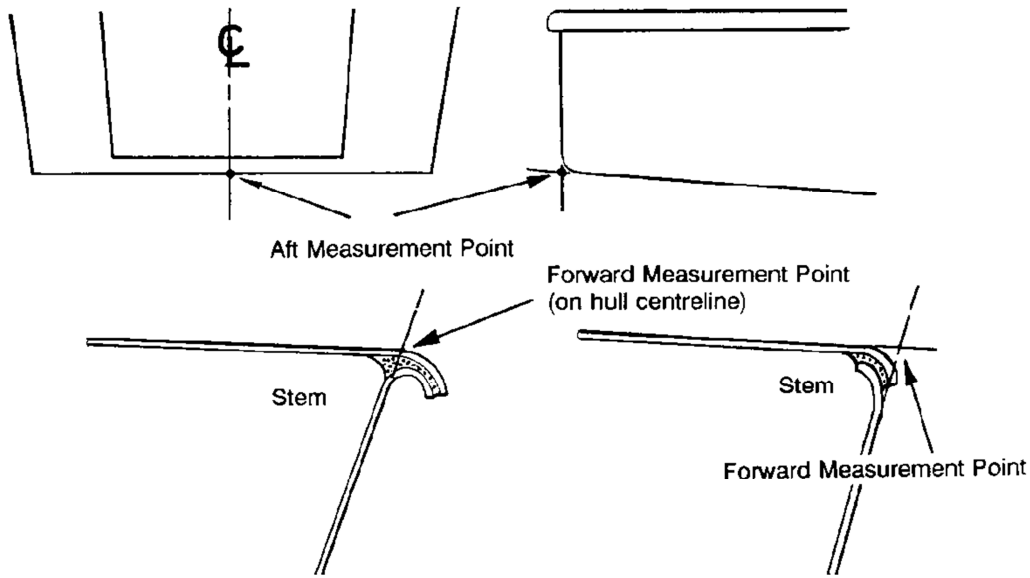

Measurement References

For measurement, the hull shall be set as in D.3.2, see Figure “Hull Measurement”.

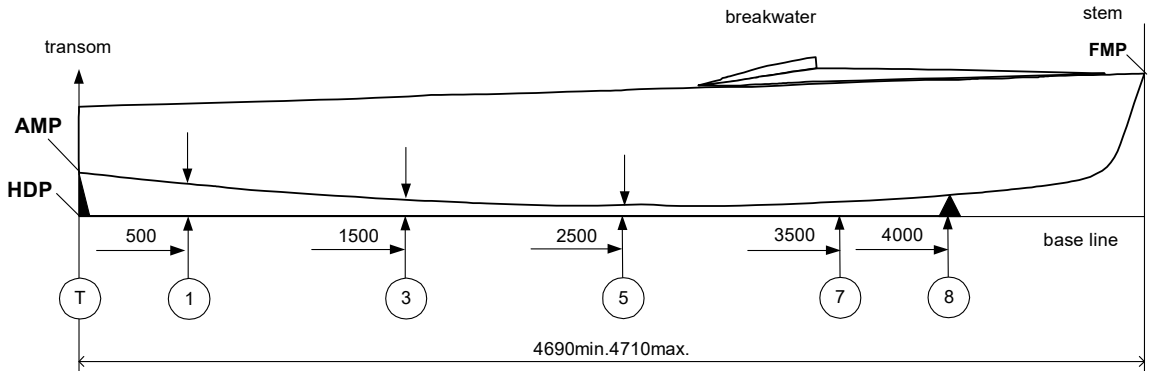

Hull Measurement

All longitudinal measurements carried out from the **hull datum point** are taken parallel to the baseline.

Certification control shall be performed at the following Sections: T, 1, 3, 5, 7, and 8. Hulls **certified** after January 1st 2013 shall be produced in moulds approved by prototype measurement performed on all 10 measurement sections. For those hulls, if the **official measurer** is in doubt about their conformity to the rules and lines plans he may control any of the additional sections.

For Sections 4 & 5 which lay in the area of the centreboard case, the distance to the baseline is measured to the prolongation of the hull, as in Figure “Measurement of Sections 4 & 5”.

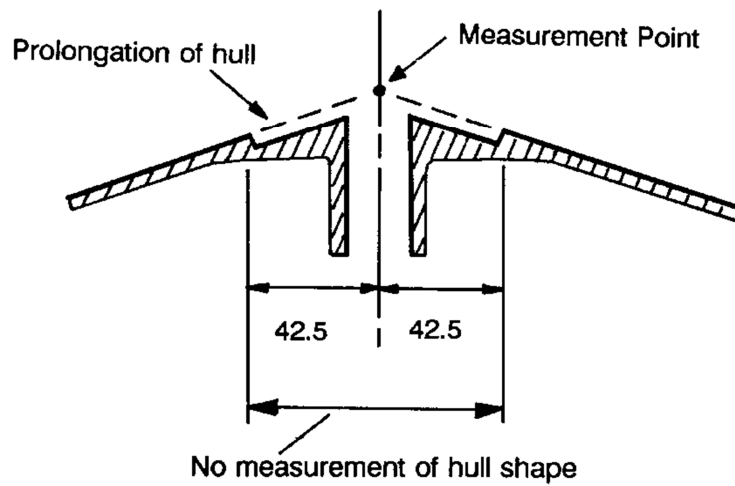

Measurement of Sections 4 & 5

D.4.2 STEM

The stem template shall be applied as shown on the “Stem measurement” Figure:

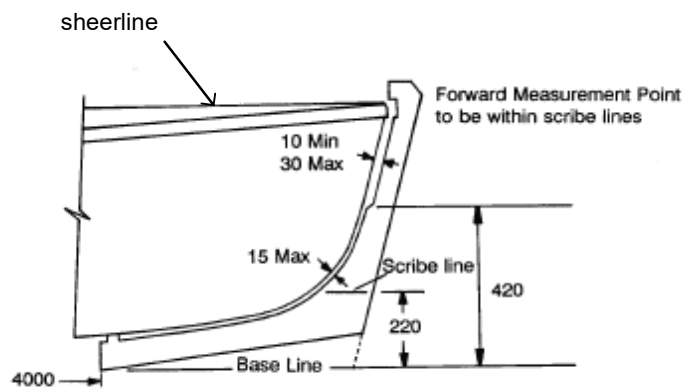

Stem Measurement

Between the sheerline and a point 420mm above the baseline the template shall clear by not less than 10mm nor more than 30mm.

Below the 420mm point the template shall touch lightly or clear by not more than 15mm.

D.4.3 ATHWARTSHIPS

Templates for the transom and sections 1 to 9 shall be applied as shown on the “Hull profile” figure:

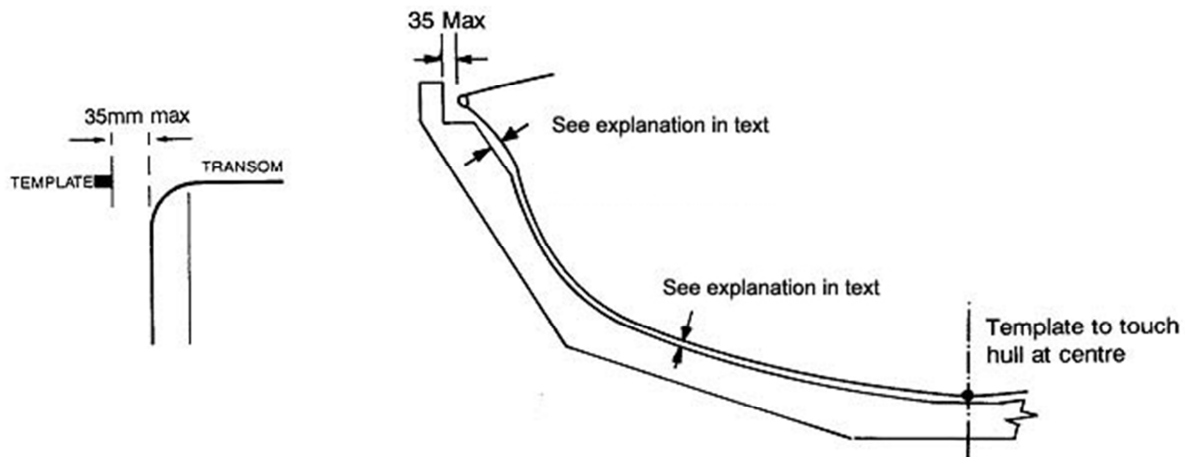

Hull Profile

The top of the deck at the sheerline shall not be more than 10mm above or below the sheer marks on the templates.

The templates shall touch the gunwale rubbing strakes lightly or clear by not more than 35mm. At the transom the distance to the template shall be defined as shown in the diagram.

Below the points 420mm above the baseline the clearance between the hull shell and the templates shall be between 5mm and 15mm at the transom and between 3mm and 17mm at sections 1 to 9.

The difference between the maximum and minimum clearances shall not exceed 7mm at the transom and 10mm at the other sections.

Above the line 420mm from the baseline, the maximum distance of the surface of the hull from the templates shall be 21mm ± 13mm at section 2, 22mm ± 13mm at section 3, 23mm ± 13mm at section 4, 31mm ± 13mm at section 5, 38mm ± 13mm at section 6 and 41mm ± 13mm at section 7.

Above the line 520mm from the baseline the maximum distance of the surface of the hull from the templates shall be 28mm ± 13mm at section 8 and 23mm ± 13mm at section 9.

The hull surface shall be tested with a flexible batten to ensure that the shape is fair.

D.4.4 CENTREBOARD PIVOT

The position of the centre of the centreboard pivot shall be measured as in Figure "Centreboard Pivot Position". The distance of the centre of the centreboard pivot from the HDP shall be 2650mm ± 10mm and its height above the prolongation of the hull at the centreplane shall be 102mm ± 10mm.

The pivot pin shall pass through the centreboard case sides and be in a fixed position. The center of the centreboard case side holes and the pivot pin axis must coincide and the maximum permitted difference between the centreboard case holes and pivot pin diameters is 2 mm.

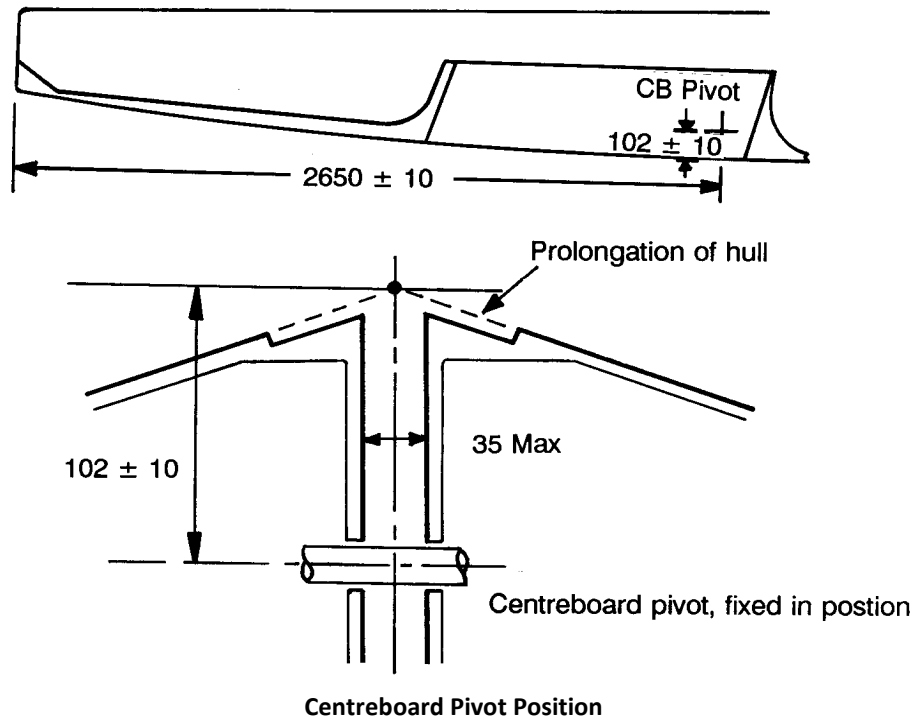

D.4.5 FOREDECK

At section 7, the centre of the foredeck shall be not more than 75mm above the top of the deck at the sheerline.

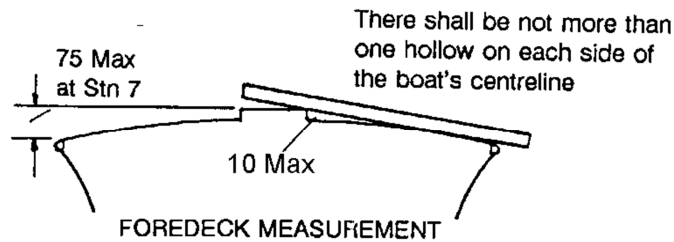

A straight edge placed on the centreline of the foredeck shall be nowhere more than 5mm from the deck.

At the centreline the aft face of the breakwater shall be 3250mm ± 30mm forward of the HDP and at the sheer 2830mm ± 30mm.

D.4.6 SIDE TANKS

The shape of the side tanks surface above 280mm from the hull is measured by a template at Section 4.

The template shall touch the tank lightly or clear by not more than 35mm.

The distance between the tanks (intersection with the hull shell) shall be verified at the transom (580mm), at Section 4 (830mm), and at Section 6 (770mm) with a tolerance of ± 30mm.

Edge of template located at inner edge of wooden rubbing strake. Where there is no wooden rubbing strake, a point 30mm from the outer edge shall be used.

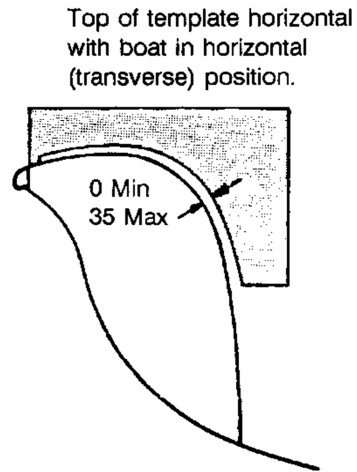

D.4.7 TRANSOM

The transom surface shall be perpendicular to the baseline, with the vertical and horizontal tolerances defined in the Figure "Transom tolerances".

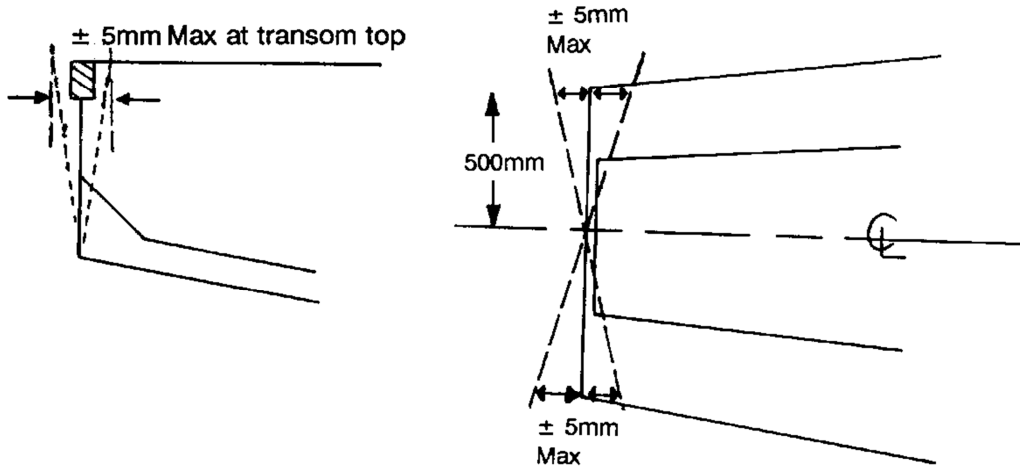

Transom Tolerances

Section E – Hull Appendages

E.1 RULES

- (a) **Hull appendages** shall comply with the current **class rules**.

E.2 MANUFACTURERS

- (a) No license is required.

E.3 CENTREBOARD

E.3.1 MATERIALS

The **centreboard** shall be made from one or a combination of the following materials; wood, plywood, polyester reinforced with glass fibre, epoxy reinforced with glass fibre and/or plastic foam which includes micro balloons and may be painted.

E.3.2 FITTINGS

OPTIONAL

- (1) Blocks and associated fittings for hoisting/lowering the **centreboard**.
- (2) A bushing around the pivot of the centreboard. It must be either fixed to the centerboard so that there is no relative movement between the two or, if circular in section, it should be concentric.

E.3.3 DIMENSIONS

- (a) Dimensions shall conform to the figures “Centreboard measurement” and “Centreboard Lower edge Shape” in E.3.4.
- (b) The **centreboard** shall be of even thickness throughout, minimum 20mm and maximum 24 mm, except that the edges may be bevelled over distances of 110 mm from the trailing and lower edges, and 55 mm from the leading edge.
- (c) Except for permitted bevelling, the thickness shall not vary by more than 1 mm.
- (d) The **centreboard** shall not be pierced by lightening holes.

E.3.4 CENTREBOARD MEASUREMENT DIAGRAMS

The contour of the centreboard is defined by the points A, origin O, E, G, the lines (GH) and (AI), as Figure “Centreboard Measurement” shows.

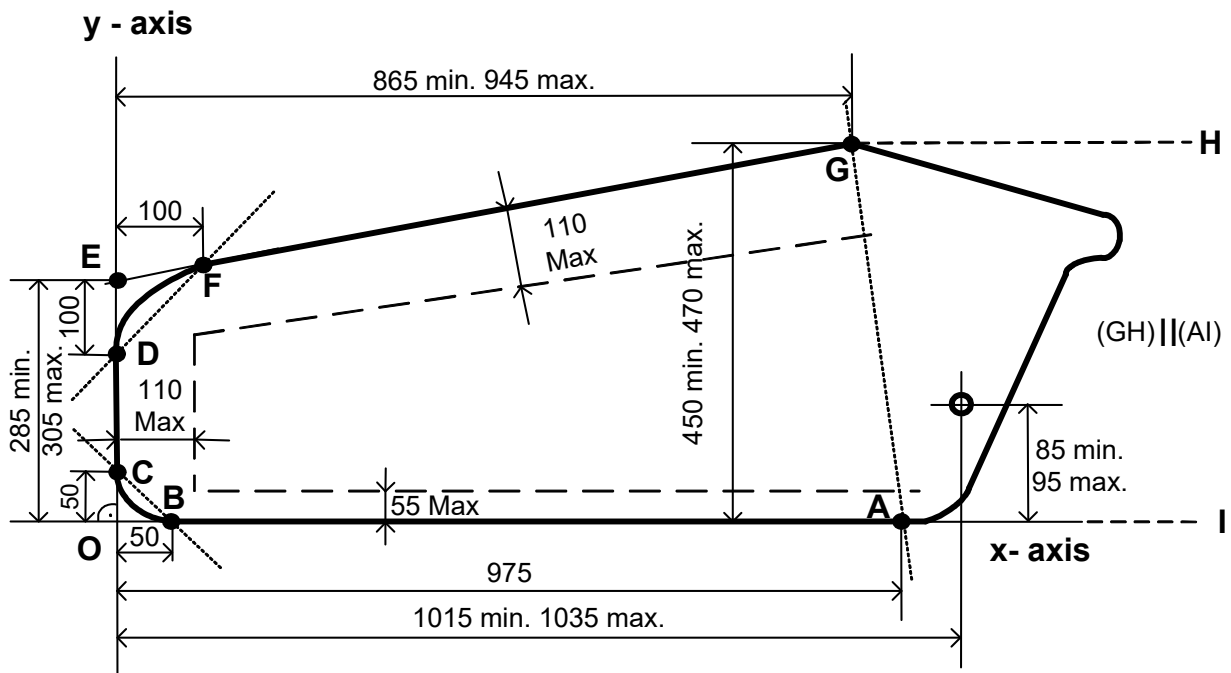

Centreboard Measurement

(a) DEFINITIONS OF MEASUREMENT POINTS AND LINES

The centreboard shall touch points A, B and C. These points are integral to the centre board.

The x and y axes are square to each other.

A is the point on the centreboard leading edge and on the x-axis 975mm from the origin O.

B is the point on the centreboard leading edge and on the x-axis 50mm from the origin O.

C is the point on the centreboard lower edge and on the y-axis 50mm from the origin O.

F is the point on the centreboard trailing edge 100mm from the y-axis.

G is the widest point of the centreboard on the trailing edge.

Point E is the extension of the trailing edge (FG) on the y-axis.

D is the point on the lower edge 100mm from point E, measured along the y-axis.

(b) DIMENSIONS

	minimum	maximum
Distance from the centre of the pivot hole to the x-axis.....	85 mm	95 mm
Distance from the centre of the pivot hole to the y-axis.....	1015 mm	1035 mm
Distance from D to the y-axis.....		2 mm
Distance from E to the x-axis.....	285 mm	305 mm
Distance from G to the outmost point of the leading edge (AB).....		470 mm
Distance from G to the innermost point of edge (AB).....	450 mm	
Distance from G to the y-axis.....	865 mm	945 mm
Total (positive, negative or both) deviation of an edge from a straight line:		
Between points A and B from the x-axis.....		2 mm
Between points C and D from line (CD)		2 mm

Between points F and G from line (FG)..... 2 mm
 Difference between centreboard pivot pin diameter
 and centreboard pivot hole or bushing's internal diameter..... 1 mm
 Line (AI) lies on the x-axis. Line (GH) is parallel to the x-axis. The length of the lines (AI)
 and (GH) is arbitrary. The contour of the centreboard inside the area AGHI is free, but
 no part of the centreboard shall lie outside this area.

The shape of the lower corners of the centreboard shall lie within the shaded areas in
 the Figure "Centreboard Lower Edge Shape", and no part of the bottom edge of the
 centreboard shall lie outside the polygon formed between points B, B', C', D', F' and F.
 Point B' is the point on the x-axis 15mm from origin O.
 Point C' is the point on the y-axis 15mm from origin O.
 Point D' is the point on the y-axis 30mm from point E.
 Point F' is the point on line (EG), 30mm from point E.

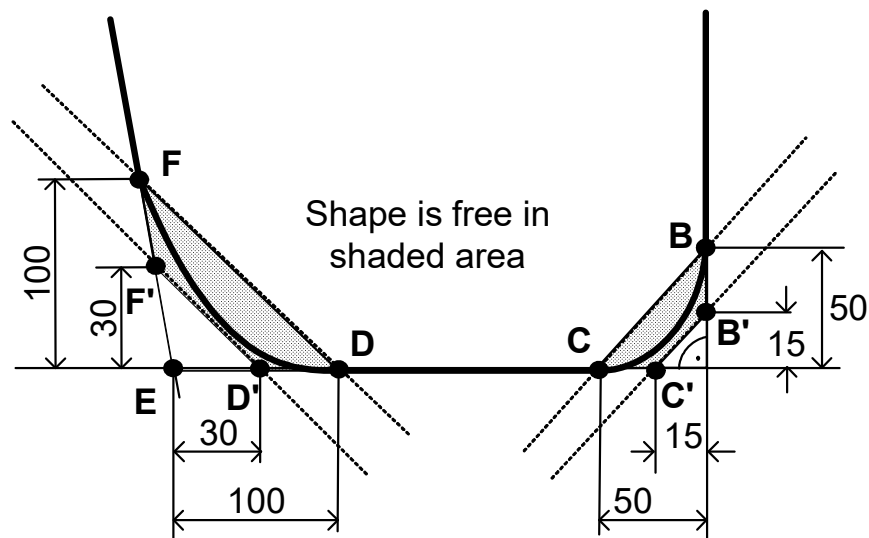

Centreboard Lower Edge Shape

E.3.5 WEIGHTS

	minimum	maximum
(1) Weight in dry condition excluding fittings and bushing	4.5 kg	6.5 kg
(2) Corrector weights are not permitted.		

E.4 RUDDER BLADE, STOCK AND TILLER

E.4.1 MATERIALS

- (a) The **rudder** blade shall be made of one or a combination of the following materials; wood, plywood, polyester with glass fibre, epoxy with glass fibre and/or plastic foam, which includes micro balloons and may be painted.
- (b) For boats first **certified** after 1st March 2002, the **rudder** stock and tiller shall be made of aluminium alloy and/or stainless steel.
- (c) The **rudder** stock shall not act as an extension of the hull

E.4.2 FITTINGS

(a) OPTIONAL

- (1) Control lines and two cleats may be used to fix the position of the **rudder** blade. One block per cleat is permitted. The control lines may turn around the rudder stock.
- (2) A bushing round the pivot of the **rudder** blade
- (3) The control lines may be fixed on the **rudder** blade by an eye strap.
- (4) A tiller extension, which may be telescopic and of any material.

E.4.3 DIMENSIONS

- (a) Dimensions shall conform to the Figures "**rudder** blade measurement" and "**Rudder** blade Lower Edge Shape" shown in E.4.4
- (b) The **rudder** blade shall be of even thickness throughout, minimum 20mm and maximum 24 mm, except that the edges may be bevelled over distances of 70mm from the trailing and lower edges and 55mm from the leading edge.
- (c) Except for permitted bevelling, the thickness of the **rudder** blade shall not vary by more than 1 mm.

E.4.4 RUDDER BLADE MEASUREMENT DIAGRAM

The contour of the **rudder** blade is defined by the points A, origin O, E, G, and lines (GH) and (AI), as Figure "**Rudder** Blade Measurement" shows.

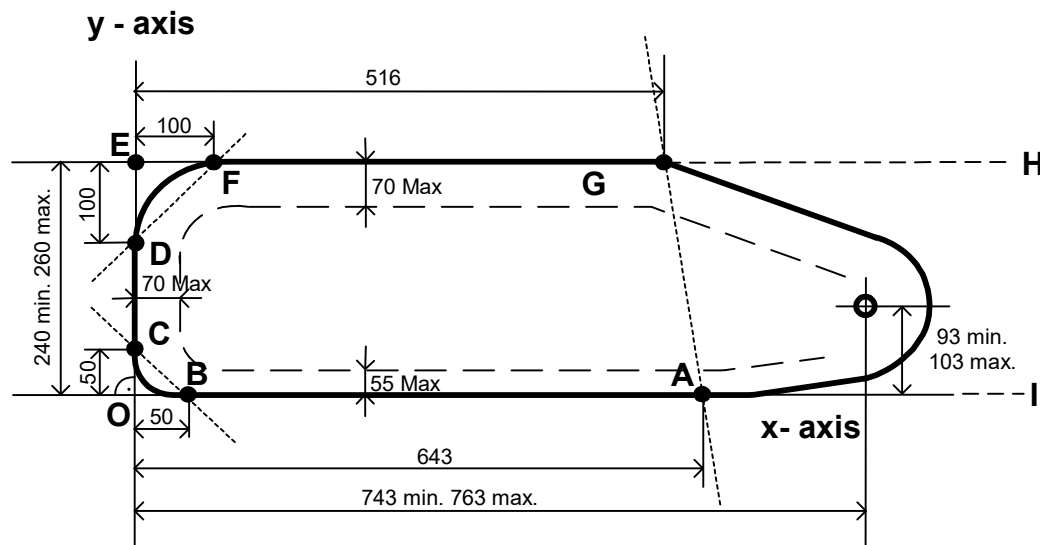

Rudder Blade Measurement

(a) DEFINITIONS OF MEASUREMENT POINTS AND LINES

The **rudder** blade shall touch points A, B and C. These points are integral to the rudder blade.

The x and y axes are square to each other.

A is the point on the **rudder** leading edge and on the x-axis 643mm from the origin O.

B is the point on the **rudder** leading edge and on the x-axis 50mm from the origin O.

C is the point on the **rudder** lower edge and on the y-axis 50mm from the origin O.

Point F is the point on the trailing edge 100mm from the y-axis.

Point G is the point on the trailing edge 516mm from the y-axis.

Point E is the extension of the trailing edge (FG) on the y - axis.

The trailing edge (FG) is parallel to the x-axis: the distance of point (G) from the outmost point of the leading edge, measured along y-axis, shall be equal to width (OE) within 2mm.

Point D is the point on the lower edge 100mm from point E, measured along the y-axis.

(b) DIMENSIONS

	minimum	maximum
Distance from the centre of the pivot hole to the x-axis.....	93 mm	103 mm
Distance from the centre of the pivot hole to the y-axis.....	743 mm	763 mm
Distance from E to the x-axis.....	240 mm	260 mm
Distance from D to the y-axis.....		. 2 mm
Total (positive, negative or both) deviation of an edge from a straight line:		
Between points A and B from the x-axis.....		2 mm
Between points C and D from line (CD)		2 mm
Between points F and G from line (FG).....		2 mm

At no point the width of the **rudder** blade shall be more than 260mm or less than 240mm.

Line (AI) lies on the x-axis. Line (GH) is parallel to the x-axis. The length of the lines (AI) and (GH) is arbitrary. The contour of the **rudder** blade inside the area AGHI is free, but no part of the **rudder** shall lie outside this area.

The shape of the lower corners of the **rudder** blade shall lie within the shaded areas in the Figure “**Rudder Blade lower Edge Shape**” and no part of the bottom edge of the **rudder** shall lie outside the polygon formed between points B, B', C', D', F' and F.

Point B' is the point on the x-axis 15mm from origin O.

Point C' is the point on the y-axis 15mm from origin O.

Point D' is the point on the y-axis 45mm from point E.

Point F' is the point on line (EG), 45mm from point E.

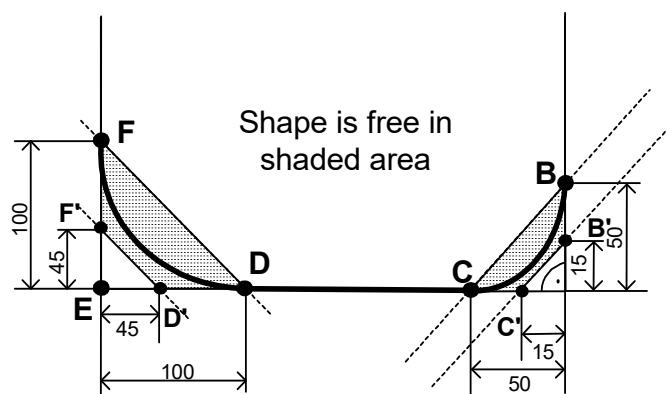

Rudder Blade Lower Edge Shape

E.4.5 WEIGHTS

The **rudder** blade, dry, with control ropes only: minimum
2.3kg

If the **rudder** blade weight is found to be underweight the difference shall be made up by **corrector weights** permanently bonded to the upper edge surface.

Section F – Rig

F.1 RULES

- (a) **Rigs** shall comply with the current **class rules**.

F.2 MANUFACTURERS

- (a) No license is required.

F.3 MAST

F.3.1 DEFINITIONS

- (a) MAST DATUM POINT

The **mast datum point** (MDP) is the **heel point**. Unless indicated otherwise, all measurements are from the MDP.

F.3.2 MATERIALS

- (a) The mast **spar** shall be of aluminium alloy.

F.3.4 CONSTRUCTION

- (a) The **spar** shall include a fixed sail groove or track, which may or may not be integral to the **spar**.

F.3.5 FITTINGS

- (a) MANDATORY

- (1) A gooseneck
- (2) Kicking strap attachment(s)
- (3) Spinnaker pole fitting.
- (4) Spinnaker pole downhaul system.
- (5) Spinnaker pole lift system.
- (6) A pair of fixed or adjustable metal **spreaders** with optional attachment systems which may include local reinforcement as per F.3.6
- (7) Jib halyard system.
- (8) Attachments for **shrouds, forestay** and **trapezes**.
- (9) Spinnaker halyard system.
- (10) Mainsail halyard system.
- (11) A device to ensure compliance with C.10.4 (b) (4) unless the mainsail halyard is set on a lock or tooth rack.
- (12) Permanently painted/taped **limit marks**.

- (b) OPTIONAL

- (1) A heel fitting
- (2) Fitting(s) for centreboard system.
- (3) Cunningham system.
- (4) Reinforcement as per F.3.6.
- (5) A removable timing device bracket

- (6) Bracket for removable compass.
- (7) A fitting to attach mainsail **tack**.
- (8) Devices attached to the **spreaders** to prevent the spinnaker halyard from getting tangled
- (9) A masthead fitting.
- (10) One mechanical wind indicator.

F.3.6 DIMENSIONS

	minimum	maximum
Mast spar curvature when loaded at 3500 mm from the mast datum point , and supported horizontally at the upper point and a point not more than 100mm from the heel:		
fore-and-aft (load 25kg).....		200 mm
transverse (load 15kg).....		130 mm
Mast spar Curvature		40 mm
Mast spar cross section between MDP and 5010 mm;		
Transverse	55 mm	75 mm
Mast spar cross section between 1550 mm and 5010 mm;		
fore-and-aft	65 mm	75 mm
In this region the mast section shape and wall thickness excluding external luff groove shall be constant along the length of the spar. Reinforcement is permitted in the regions of the mast partner, spreaders and the connection if the mast is made of two parts. A cut-off for sail entry is permitted.		
Mast limit mark width		10 mm
Lower point height		1055 mm
Upper point to the lower point		5750 mm
Forestay height	4995 mm	5025 mm
Trapeze height	4910 mm	5110 mm
Shroud height	4995 mm	5025 mm
Distance between the aft face of the mast and the gooseneck pivot.....		35 mm
Spinnaker pole fitting:		
height	1240 mm	1260 mm
projection		40 mm
Spinnaker hoist height		5170 mm
Spinnaker halyard projection device, distance from spar		60 mm
Spreader height	2790 mm	2810 mm
Headsail hoist height		4870 mm
Mast centre of gravity height.		
The rigging parts to be included in the measurement are those under F.6.2; F.7.2 (a). The trapeze system shall only include the wire and the handhold.....		2800 mm

F.3.7 WEIGHTS

The weight of the **mast** includes rigging specified under F.6.2; F.6.3 (a) (1), F.7.2 (a), fittings specified under F.3.5 and riveted or adhesively bonded compass bracket if applicable, but without wind indicator, compass and/or timing device & bracket:

	minimum	maximum
Mast weight	10 kg	
Mast corrector weights		0.3 kg

Corrector weights shall be permanently attached so that no part of the corrector is more than 200mm from the **upper point**.

F.4 BOOM

F.4.1 MATERIALS

(a) The boom **spar** shall be of aluminium alloy.

F.4.2 CONSTRUCTION

(a) The **boom** shall include a fixed aluminium sail groove or track which may or may not be integral with the **spar**.

F.4.3 FITTINGS

(a) MANDATORY

- (1) A gooseneck attachment fitting.
- (2) A kicking strap (boom vang) fitting.
- (3) Mainsheet block(s) with attachment fitting(s) for the blocks and/or mainsheet which may be adjustable
- (4) Mainsail **clew** outhaul attachment or adjustment system.
- (5) A device to ensure compliance with C.10.4(b).(5).
- (6) Permanently painted/taped **limit mark**.

(b) OPTIONAL

- (1) A fitting to attach mainsail **tack**
- (2) A **spar** end fitting
- (3) The **spar** may be protected in the area where it touches the shrouds by pieces of any material, with maximum length/height/thickness = 100/50/5 mm.

F.4.4 DIMENSIONS

	minimum	maximum
Boom spar deflection when loaded with 80 kg at a point midway between points 100 mm from each end and with the groove uppermost:		
vertical		50 mm
Boom spar cross section		
vertical	54 mm	72 mm
transverse	38 mm	

Radius of convex edges excluding those of external or internal tracks or grooves.....5 mm

The boom section shall be constant except within 150 mm from each **spar** end excluding any end fittings.

Limit mark width 10 mm

Outer point distance 2650 mm

F.5 SPINNAKER POLE

F.5.1 MATERIALS

(a) The spinnaker pole **spar** shall be of aluminium alloy.

F.5.2 FITTINGS

(a) OPTIONAL

(1) An end fitting at each end.

(2) Fittings approximately at the mid-point for attachment for lift/downhaul.

(3) A fixed line between the fittings described in F.5.2 (a) (1), which may incorporate knots, toggles or short tubes for easier handling.

F.5.3 DIMENSIONS

Spinnaker pole length maximum
.....1900 mm

F.6 STANDING RIGGING

F.6.1 MATERIALS

(a) Unless otherwise specified, the standing **rigging** shall be of stainless steel wire rope. Rod rigging is prohibited.

F.6.2 CONSTRUCTION

(a) MANDATORY

(1) A **forestay** of a diameter not less than 2.3 mm.

(2) Two **shrouds** of a diameter not less than 2.3 mm.

(b) OPTIONAL

(1) Shock-cord may be fitted between the **forestay** and the stemhead fitting, to maintain tension in the **forestay**.

F.6.3 FITTINGS

(a) MANDATORY

(1) **Forestay** attachment fittings.

(2) Each **shroud** shall be attached to the shroud plate by means of plates having rows of adjustment holes. No other arrangement of shroud adjustment is permitted.

F.7 RUNNING RIGGING

F.7.1 MATERIALS

(a) Materials are optional.

F.7.2 PARTS

(a) MANDATORY

- (1) Mainsail halyard
- (2) Headsail halyard
- (3) Spinnaker halyard
- (4) Spinnaker pole lift and downhaul

(b) OPTIONAL

- (1) Mainsail Cunningham line
- (2) Mainsail outhaul
- (3) Mainsail tack attachment

F.7.3 FITTINGS

(a) OPTIONAL

- (1) One block or eye in each headsail Barber hauler to run on headsail sheet
- (2) One block or eye in each spinnaker Barber hauler to run on spinnaker sheet or guy.

F.8 OTHER RIGGING

F.8.1 PARTS

(a) MANDATORY

- (1) 1 **trapeze** on each side of the boat. The material of the **trapeze** is optional, if wire rope is used it shall have a diameter not less than 2.3 mm. Each **trapeze** system may be provided with handholds, rings and adjustment. Self-tacking **trapeze** systems are not permitted.

(b) OPTIONAL

- (1) Elastic cord(s) on each **trapeze** connected to the **shrouds** or between **trapezes**.

Section G – Sails

G.1 PARTS

G.1.1 MANDATORY

- (a) Mainsail
- (b) Jib

G.1.2 OPTIONAL

- (a) Spinnaker

G.2 GENERAL

G.2.1 RULES

- (a) **Sails** shall comply with the current **class rules**.
- (b) Jibs may be measured with battens inside the **batten pockets**.
- (c) Jibs shall be measured with the luff wire removed.
- (d) The following applies to jibs **certified** after January 1, 2014:
 - (i) When the **clew** or the **tack** has a cut-out, the **corner point** shall be found by extending the associated **sail edges** beyond the cut-out starting points and then finding the intersection point, as shown in diagrams G.4.2.f(a) and G.4.2.g(a).
 - (ii) An FRP batten of uniform stiffness and approximately 2 mm in thickness shall be used to create **sail edge** extensions.
 - (iii) Not more than 50mm of the batten's length shall be used for **sail edge** extension purposes.
 - (iv) The batten shall be held at points outside the part used for extensions.
 - (v) The batten shall be positioned with one point approximately at the expected **corner point** and a second point touching the **sail edge** to be extended at not more than 50mm away from the first point.
 - (vi) If the **sail edge** is curved, the batten shall be bent to follow the **sail edge** between the cut-out starting point and the second point described in (v). See the diagrams in G.4.2(f) & (g).
 - (vii) The procedure above shall be repeated to find the other **sail edge** extension.

G.2.2 CERTIFICATION

- (a) The **official measurer** shall **certify** mainsails and jibs in the **tack** and spinnakers in the **head** and shall sign and date the **certification mark**. Sails may be **certified** without identification on them.
- (b) Sails shall carry the sail button/sticker issued by the ICA attesting that the class fee has been paid, and located for mainsails and jibs in the tack and spinnakers in the head.
- (c) WS or an MNA may appoint one or more **In-House Official Measurers** to measure and **certify sails** produced by that manufacturer.

G.2.3 SAILMAKER

- (a) The sailmaker is optional.

G.3 MAINSAIL

G.3.1 INSIGNIA

- (a) The mainsail shall carry the 470 insignia in dark blue paint or other durable material, securely attached.
- (b) The 470 insignia shall be placed under and in close proximity to the upper batten pocket and shall conform to the Figure “470 Insignia” with a tolerance of 2mm.

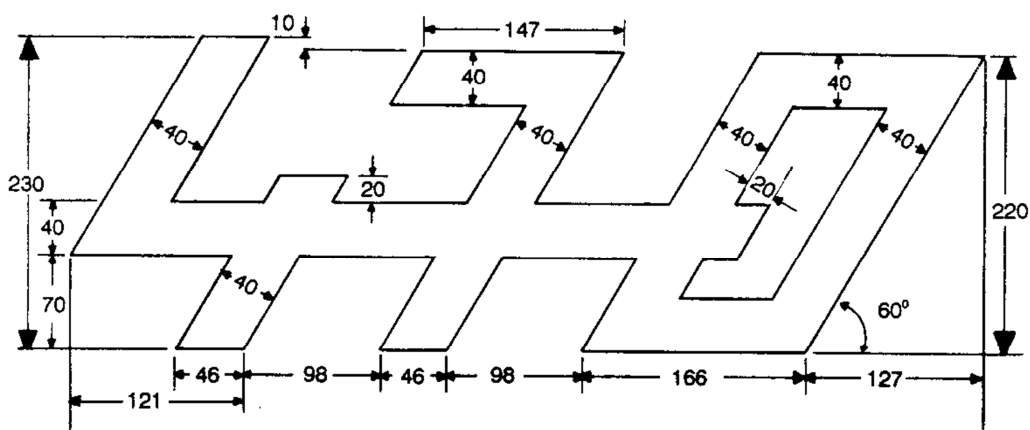

470 Insignia

G.3.2 MATERIALS

- (a) **Body of the sail** permitted material is **woven ply** with polyester fibres.
- (b) Battens may be made of any material.
- (c) **Primary** and **secondary reinforcement** permitted material is **woven ply** with polyester fibres.

G.3.3 CONSTRUCTION

- (a) The construction shall be: **soft sail, single ply sail**.
- (b) The **body of the sail** shall consist of the same **woven ply** throughout except for the panel adjacent to the **foot**, which may be of a different **woven ply**. This limitation does not apply for the colour of the ply, which may differ from panel to panel.
- (c) The **sail** shall have three **batten pockets** in the **leech**.
- (d) The **leech** shall not extend aft of straight lines between:
- (1) the **aft head point** and the intersection of the **leech** and the upper edge of the nearest **batten pocket**,
 - (2) the intersection of the **leech** and the lower edge of a **batten pocket** and the intersection of the **leech** and the upper edge of an adjacent **batten pocket** below,
 - (3) the **clew point** and the intersection of the **leech** and the lower edge of the nearest **batten pocket**.
- (e) The following are permitted: Stitching, glues, tapes, bolt ropes, corner eyes, headboard with fixings, Cunningham eye or pulley, **chafing patches**, **batten pocket patches**, **batten pocket** associated fittings, top batten pocket end cap at luff end

and tensioning device at leech end, leech line with cleat on leech, not more than two **windows**, one boom slide fixed at the **clew**, tell tales, sail shape indicator stripes, sail identification, sailmaker labels, sail button/sticker, **certification mark**.

G.3.4 DIMENSIONS

	minimum	maximum
Leech length		6265 mm
Quarter width		2340 mm
Half width		1790 mm
Three-quarter width		1050 mm
Top width		140 mm
Thickness of ply of the body of the sail	0.165 mm	
Primary reinforcement		325 mm
Secondary reinforcement:		
from sail corner measurement points		1000 mm
from the leech		300 mm
area above top batten pocket		unlimited
Foot boltrope length	2200 mm	
Total window(s) area		0.3 m ²
Window to sail edge	150 mm	
Distance of headboard stiffening from head point		140 mm
Intermediate and lower Batten pocket inside length:		800 mm
Intersection of a batten pocket centreline and leech to adjacent cross width measurement point		100 mm
Head point to intersection of luff and centreline of uppermost batten pocket when the luff is under sufficient tension to remove wrinkles	1680 mm	1780 mm
Chafing patch		300 mm
Intermediate and lower batten length		800 mm

G.4 JIB

G.4.1 MATERIALS

- Body of the sail** permitted material is **woven ply** with polyester fibres
- Battens may be made of any material.
- Primary and secondary reinforcement permitted material is woven ply with polyester fibres

G.4.2 CONSTRUCTION

- The construction shall be: **soft sail, single ply sail**.
- The **body of the sail** shall consist of the same **woven ply** throughout. This limitation does not apply for the colour of the **ply**, which may differ from panel to panel.
- The jib shall have a maximum of three **batten pockets** in the **leech**.

- (d) The **leech** shall not extend beyond a straight line from the aft **head point** to the **clew point**.
- (e) The following are permitted: Stitching, glues, tapes, **tabling**, corner eyes, **chafing patches**, **flutter patches**, **batten pocket patches**, not more than two **windows**, tell tales, sail shape indicator stripes, sail identification, sailmaker labels, sail button/sticker, **certification mark**.
- (f) Only the following **tack** construction arrangements are permitted for jibs **certified** after January 1 2017.

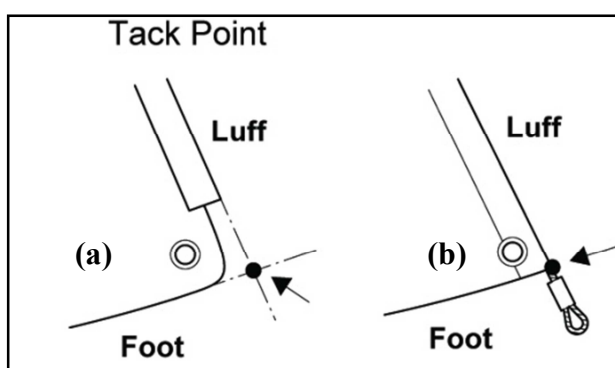

- (g) Only the following **clew** construction arrangements are permitted for jibs **certified** after January 1 2017.

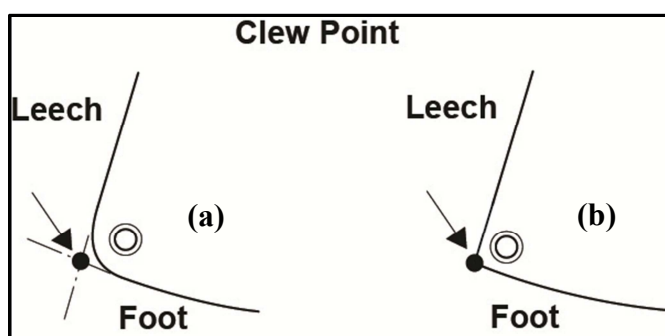

G.4.3 DIMENSIONS

	minimum	maximum
Luff length		4100 mm
Leech length		3750 mm
Foot length		1955 mm
Foot median		3950 mm
Top width		30 mm
Foot irregularity		30 mm
Thickness of ply of the body of the sail	0.165 mm	
Primary reinforcement		275 mm
Secondary reinforcement:		
from sail corner measurement points		750 mm
Total Window(s) area		0.3 m ²

Window to sail edge	150 mm
Batten pocket inside length:	250 mm
Chafing patch	350 mm
Flutter patch	100 mm

G.5 SPINNAKER

G.5.1 MATERIALS

- (a) **Body of the sail** permitted material is **woven ply** with polyester or nylon fibres.
- (b) **Primary** and **secondary reinforcement** permitted material is **woven ply** with polyester or nylon fibres.

G.5.2 CONSTRUCTION

- (a) The construction shall be: **soft sail, single ply sail**.
- (b) The **body of the sail** shall consist of the same **woven ply** material throughout. This limitation does not apply for the colour of the **ply**, which may differ from panel to panel.
- (c) The following are permitted: Stitching, glues, tapes, corner eyes, tape eyes, tell tales, sail shape indicator stripes, sail identification, sailmaker labels, sail button/sticker, **certification mark**.

G.5.4 DIMENSIONS

	minimum	maximum
Leech lengths		4360 mm
Foot length		3000 mm
Foot Median		5100 mm
Difference between diagonals		50 mm
Upper width (upper leech points at 200 mm from head point)		350 mm
Half width		3450 mm
Three-quarter width		1830 mm
Primary reinforcement		300 mm
Secondary reinforcement		unlimited

OFFICIAL PLANS

1	Building Specification Plan	2023
2	Lines Plan	2011
3	Class Insignia (Full size)	2011
4	Full Size Sections	2011
5	Full Size Templates	2011
6	Full Size detail of Stem	2011

Published Date 15th June 2023

Effective Date: 15th June 2023

Previous issue: 1st January 2023

© World Sailing