



# Iate Clube do Rio de Janeiro



## 2018 STAR SOUTH AMERICAN CHAMPIONSHIP

07<sup>TH</sup> to 11<sup>th</sup> of November 2018

Iate Clube do Rio de Janeiro

Rio de Janeiro - Brazil

### SAILING INSTRUCTIONS



#### 1. Rules

- 1.1 The regatta will be governed by the rules as defined in *The Racing Rules of Sailing (RRS)*.
- 1.2 No national prescriptions will apply.
- 1.3 RRS Appendix P will apply. RRS P2.2 and P2.3 will be deleted.
- 1.4 Boats may carry VHF radios for purposes of safety and for receiving race committee communication, including notification of OCS boats (see SI12). No other communication devices may be used.
- 1.5 STCR 35.5 changes RRS 44.1 to a One-Turn Penalty.
- 1.6 The sailing instructions may also change other racing rules if approved by ISCYRA.
- 1.7 The amendment to STCR 31.2.6 (ISCYRA Resolution #4-2016) is in effect: boats may carry VHF radios for purposes of safety and for receiving race committee communication, including notification of OCS boats. Race Committee failure to notify, delay notification, and the order announced will not be grounds for redress.
- 1.8 If there is a conflict between languages the English text will take precedence.
- 1.9 The International Governing Committee of the ISCYRA has granted the 2018 Star Class South American Championship authority, as a "test event", to modify ISCYRA Rule 34.3.1. as follows "... no course may be shortened using RRS 32.2 (the Flag S rule) but a course leg or legs may be shortened or lengthened utilizing RRS 33(b) (Charlie + or -) within the parameters established by ISCYRA Rule 34.3.7

#### 2. Notices to Competitors

Notices to competitors will be posted on the official notice board located in front of ICRJ "coffee place" at the balcony.

#### 3. Crew Weight

Crews must comply with STCR 31.1.3 at all times.

#### 4. Changes to the Sailing Instructions

Changes in the Sailing Instructions will be approved by the Protest Committee and the Organizing Authority and will be posted before 0800 hours on the day they will take effect, except that any change in the schedule of races will be posted by 2000 hours on the day before it will take effect.

#### 5. Signals Made Ashore

- 5.1 Signals made ashore will be displayed on the Club flagpole, located in front of the Star restaurant.
- 5.2 When flag "AP" is displayed ashore, '1 minute' is replaced with 'not less than one hour' in the race signal AP.

#### 6. Schedule of Races

Wednesday, November 07 <sup>th</sup>	09:00 – 18:00	Registration, Inspection of boats, Team Weigh-In
	17:30	Open Ceremony (ICRJ Veranda) - (dress code: Blazer)
Thursday, November 08 <sup>th</sup>	09:00 – 12:00	Registration, Inspection of boats, Team Weigh-In
	10:00	Skippers Meeting
	13:00	Warning Signal 2 Races scheduled
	After Racing	Happy hour with beer
Friday, November 09 <sup>th</sup>	13:00	Warning Signal 2 Races scheduled
	After Racing	Happy hour with beer
	19:00	Star Class Dinner (Noble Room) (dress code: Blazer and Tie)
Saturday, November 10 <sup>th</sup>	13:00	Warning Signal 2 Races scheduled
	After Racing	Happy hour with beer
Sunday, November 11 <sup>th</sup>	13:00	Warning Signal 1 Race scheduled
	15:30	latest time for last Warning Signal
	After Racing	Awards Ceremony - Penguin Bar

6.2 7 races are scheduled. No more than three (3) races per day will be completed.

6.3 The scheduled time of the warning signal for the first race is each day is 13:00.

6.4 No Warning Signal will be made after 15:30 on Sunday, November 11<sup>th</sup>.



## 7. Class Flag

The Class Flag will be the Star Class logo flag.

## 8. Racing Area

8.1 The racing areas will be decided by the Race Committee, as defined in Appendix A

## 9. Courses

9.1 Course 0, Course 1, Course 3, and Course 4 may be used. Diagrams are included in Appendix B.

9.2 The approximate compass bearing from Mark 3 (or Marks 3S and 3P) to Mark 1 will be displayed in the forward rack on the Signal Boat prior to or with the Warning Signal.

9.3 Format C - Under 30 boats competing: Minimum of 1 n.m. and maximum of 1.5 n.m. legs. 30 minute maximum time limit for first beat, target time per race is 1 hour. 2 hour maximum time limit for completed course. No more than 3 races per day.

9.4 The courses will not be shortened. This changes RRS 32.

9.5 RRS 33(b) is deleted.

## 10. Marks

10.1 Mark 1, 2 on 3 will be a yellow pyramids.

10.2 If used, a 'leeward gate' will consist of a pair of yellow pyramids.

10.3 At any mark beginning a downwind leg on Course 0 or 1, the Race Committee may set an offset mark, which will be an yellow pyramids. In that case, boats shall pass both Mark 1 and the offset mark to port. For Courses 3 and 4 the offset mark will be an yellow pyramids.

10.4 A new mark will be an orange cylindrical. In the event of a change of course, an offset mark may be used and it will be the same color as the new mark.

10.5 The finishing mark will be a red cylindrical.

## 11. Check In

Prior to the first Warning Signal of the first race a boat sails each day, she shall sail past the stern of the Race Committee signal boat to be recorded. Boats not complying with this instruction will receive the same score as a boat not starting (DNS), without a hearing. This changes RRS A4, A5, and 63.1.

## 12. The Start

12.1 The starting line will be between the staff displaying an orange flag on the signal boat and the staff displaying an orange flag on the pin boat.

12.2 OCS boats may be hailed by sail number or bow number on VHF 74 (see SIs 1.4 and 23).

12.3 A boat not starting within 10 minutes after the starting signal will be scored DNS, without a hearing. This changes RRS A4, A5, and 63.1.

12.4 A Race Committee boat displaying code flag 'X', positioned near Mark 1, will attempt to notify OCS boats and will display their bow numbers.

12.5 A Race Committee boat displaying a 'U' or Black Flag, positioned near Mark 1, will attempt to notify boats that have been disqualified in accordance with RRS 30.3 or 30.4, respectively, and will display their bow numbers. Any boat notified that she has been disqualified shall leave the race course immediately. However, if there are two or more races scheduled for that day, boats having been disqualified in one race may stand by in an area outside the racecourse for the next race.

## 13. Change of Position of the Next Mark

To change the next leg of the course, the Race Committee will lay a new mark (or move the finishing line) and remove the original mark as soon as practicable. When in a subsequent change a new mark is replaced, it will be replaced by an original mark.

## 14. The Finish

The finishing line will be between the staff displaying a blue flag on a Race Committee boat and the nearby finishing mark.

## 15. Time Limit

15.1 The time limits will be as described in STCR 34.3.7, Format C.

15.2 Boats finishing more than 30 minutes after the first boat to finish will be scored 'Did Not Finish' (DNF), without a hearing. This changes RRS 35, A4, and A5.

## 16. Protests

16.1 Protest forms will be available at the protest desk at the late Clube do Rio de Janeiro, and shall be delivered there when completed.



16.2 Protest forms must be delivered within 60 minutes of the signal boat docking time. The protest time limit will be posted on the Official Notice Board. The same protest time limit applies to all protests by the Race Committee and Jury about incidents they observed in the racing area. This changes RRS 61.3 and RRS 62.2.

16.3 Notices will be posted on the Official Notice Board within 10 minutes of the protest time limit to inform competitors of hearings in which they are parties or named as witnesses. All parties and witnesses to a protest hearing shall meet at the protest desk at the scheduled hearing time.

16.4 A list of all boats that have been penalized for breaking RRS 42 will be posted as soon as practicable.

16.5 The race committee will post a list of penalties being assigned by the race committee prior to the end of the protest time limit. The deadline for requesting redress based on these scores will be either 30 minutes after the posting of the penalty notice or the protest time limit, whichever is later. This changes RRS 62.2.

16.6 On the last day of racing a request for redress based on a Jury decision shall be delivered no later than 30 minutes after the decision was posted. This changes RRS 62.2.

16.7 The penalty for breaking SI 18, 19, 20, 21, and 23 will be at the discretion of the Jury. For SI 20 the penalty may be applied to all boats associated with the team or a private support boat.

## 17. Scoring

17.1 The scoring system is the Low Point System of RRS A.

17.2 4 races are required to be completed to constitute a series.

17.3 (a) When fewer than [5] races have been completed, a boat's series score will be the total of her race scores.

(b) When [5] or more races have been completed, a boat's series score will be the total of her race scores excluding her worst score. This changes RRS A2.1.

## 18. Liability and Safety

18.1 The safety of a boat and her entire management, including insurance, shall be the sole and inescapable responsibility of the owner and/or entrant.

18.2 Competitors leaving the race before the end of a race shall inform the Race Committee or a safety boat as soon as practicable.

## 19. Crew Changes

19.1 Any request for a change of crew must be submitted to the Jury in writing prior to 0900 hours on the day of the race for which the change is to be made. If the Jury grants permission, it will post its decision on the Official Notice Board.

19.2 A change of helmsman will not be permitted.

## 20. Team and Private Support Persons and Boats

20.1 As per RRS 1.1, a Support Persons and private spectator boats are expected to render assistance to a boat in danger when requested by the boat, or at the request of the Race Committee or Jury.

20.2 Support Persons shall stay 100 meters (300 Feet) outside the areas where boats are racing from the time of the Warning Signal until all boats have finished racing for the day.

20.3 A boat shall receive no outside assistance from Support Persons once she has left the dock for the day until the finish of the last race of the day, except in the case of emergency and/or towing supplied by the Organizing Authority or requested by the Race Committee. 20.4 The penalty for breaking 20.1, 20.2, or 20.3 will be at the discretion of the Jury, up to and including disqualification of all boats associated with the team or private Support Person(s).

## 21. Haul-Out Restrictions

There will be no haul out restrictions boats ashore will be divided among the 3 cranes according the Organizing Authority.

## 22. National Authority Prescriptions That Apply

Refer to Addendum #1, posted on the Official Notice Board, and the Sailing Instructions.

## 23. Radio Communication

23.1 A boat shall limit radio transmissions while racing.

23.2 The Race Committee may hail OCS boats on VHF Channel 74. (See SI 1.4 and SI12). Failure of the Race Committee to transmit, failure of a competitor to receive, mistaken transmissions, and the order of hail shall not be grounds for granting redress. This changes RRS 62.1(a).

## 24. Prizes

Prizes will be given as follows: 1st to 5th Overall; 1st Junior (Skipper under 25 years old); 1st Master (50-59); 1st Grand Master (60-69); 1st Exalted Master (70+); 1st to 3rd Black Star (hull number under 7300)



**25. Disclaimer of Liability**

25.1 Competitors participate in this regatta entirely at their own risk. See RRS 4, Decision to Race.

25.2 Participants agree that no person or organization involved in the conduct of this Championship will be liable for any accident, injury, fatality, or damage or loss of boat or personal property arising out of a participant's preparation for and participation in any on-the-water or on-shore activities (whether social, recreational, launching, hauling, boat storage, or otherwise) associated with the Championship. Nothing in these Sailing Instructions or oral statements by the Organizing Authority, their officers, directors or agents, shall modify or otherwise impair the effect of the Waiver of Liability Form, the execution of which is a condition of entry.

## Appendix A





## Appendix B

### Star Class Courses (STCR 34.3 and 34.4)

In case of small regattas the starting line may be set up at mark 3 and the finishing line at mark 1 or mark 3.

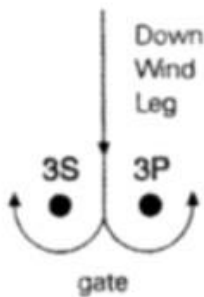

Courses 0, 1, 2, 3 and 4 are diagramed as described in STCR 34.3 and modified in the diagrams as allowed by STCR 34.4.

In Gold and Silver events, Course 0, 1, 3 or 4 shall be used. Course 2 may be used in Silver events if requested by the sponsoring fleet and approved by the Continental Committee.

In Blue and Green events Course 0, 1, 2, 3, and 4 shall be used.

No course may be shortened during Gold, Silver, Blue or Green Events.

In Red events and Qualifications the above courses are not mandatory and may be shortened.

### Course "0"

Start  
1  
2  
3  
1  
3 (or gate 3A – 3B)  
Finish (upwind)

○ = optional offset mark

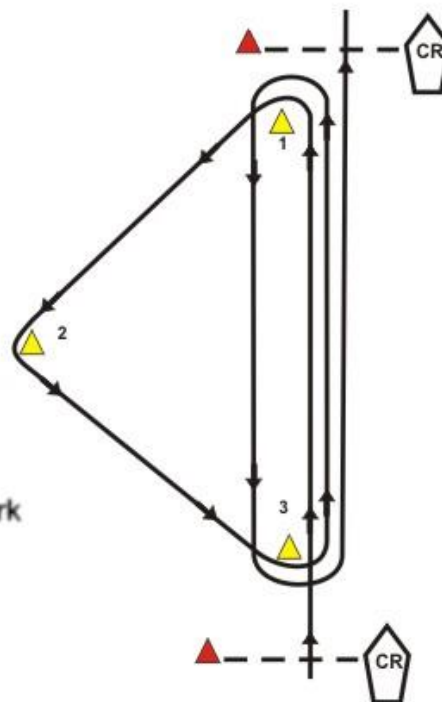

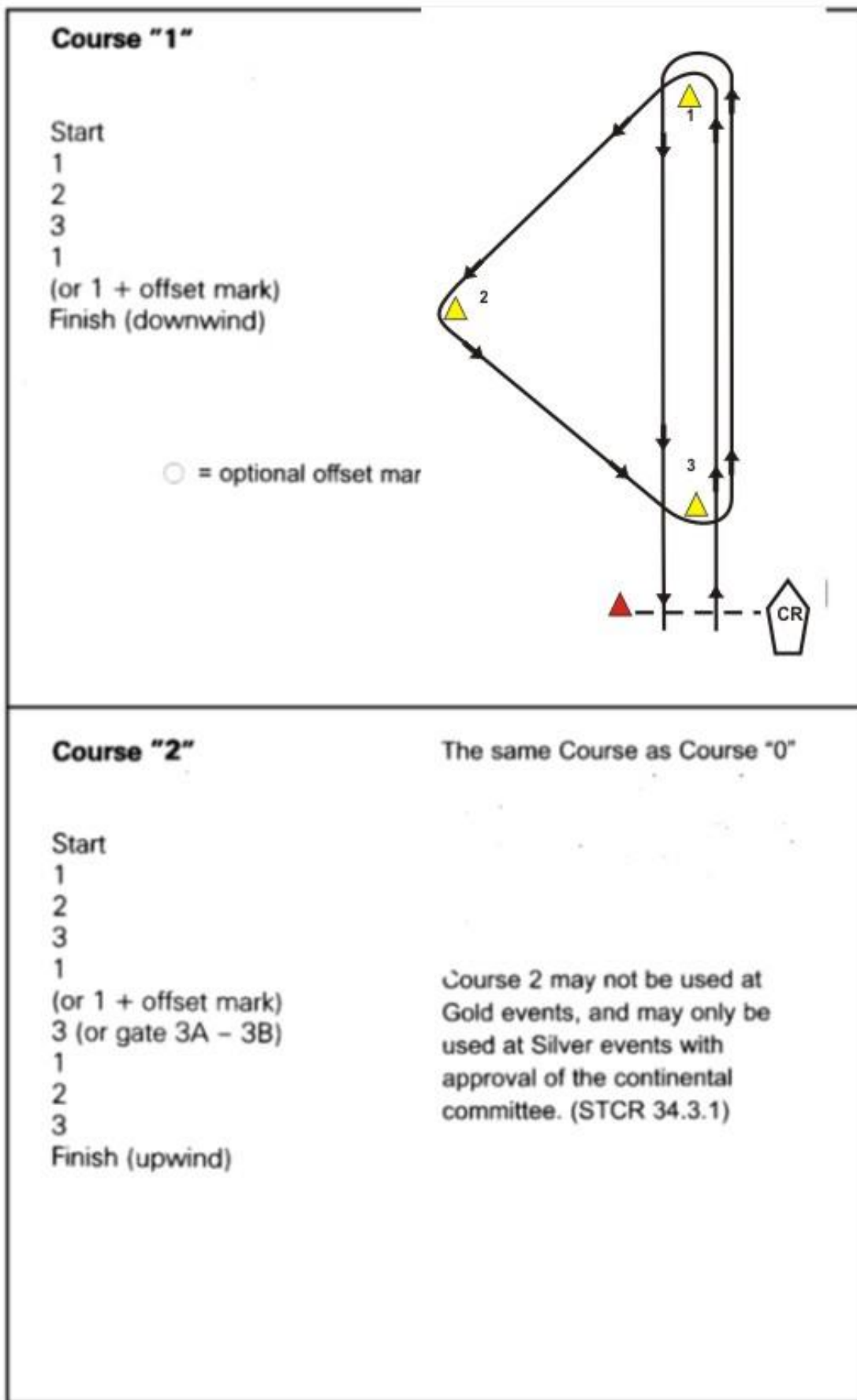



**Course "3"**

Start

- 1
- 2
- 3 (or gate 3A-3B)
- 1
- 2
- 3 (or gate 3A-3B)
- Finish (upwind)



**Course "4"**

Start

- 1
- 2
- 3 (or gate 3A - 3B)
- 1
- 2
- Finish (downwind)

